

MEDENUS

Gas Pressure Regulation



Safety relief valve SL 10



Product Information

EN

Table of Contents

Application, Characteristics, Technical Data	4
Application	4
Characteristics	4
Type of model (options)	4
Technical Data	4
Design and function	5
Valve seat diameter, measuring unit diameter	6
Control unit setpoint spring table	6
Dimensions, Connection and Weight	7
Dimensions and weight	7
Dimensional drawing	7
Connections	7
Order data	8
Contact	10
Notes	11

List of abbreviations and formula symbols

AC	Accuracy class	BV	Breather valve
HDS	High-pressure spindle	SG	Closing pressure group
Q_{max}	Maximum flow rate	t_u	Gas inlet temperature
PS	Maximum allowable pressure	VS	Valve seat
p_u	Response pressure	ρ_n	Gas density
Q_n	Standard volumetric flow rate		

Application, Characteristics, Technical Data

Application

Safety relief valve (SRV), direct-acting (operating without auxiliary power), for systems acc. to DVGW - work sheet G 491 (A) and G 600 (A) (TRGI)

Can be used as an equipment component on gas consumption facilities as defined in EC Directive (90/396/EEC)

Can be used for the gases defined in DVGW - work sheet G 260 / G 262 and neutral non-aggressive gases. (other gases on request)

Characteristics

- Integral pressure-tight version (IS)
- Class A
- Position-independent installation
- High level of response accuracy
- outdoor version as standard

Type of model (options)

- Oxygen model
- with BV breather valve

Technical Data

Type	SL 10
Model	Integral pressure-tight (IS)
Max. allowable pressure PS	8 bar
Max. inlet pressure $p_{u,max}$	3.5 bar
Nominal size	Rp 1" (DN 25), Rp 1½" (DN 40), Rp 2" (DN 50) (NPT thread on request)
Type of connection	Internal thread acc. to EN 10226-1
Material	
Housing / actuator housing	Al - cast alloy
Temperature range, Class 2 (operating/ambient temperature)	-20°C to +60°C
Accuracy class AC	5
Closing pressure group SG	10
Function, Strength and Tightness	DIN EN 33821
CE mark acc. to PED/ PIN number	CE-0085-AQ0879
Ex protection	The mechanical parts of the device do not have any potential ignition sources of their own and therefore do not fall within the scope of ATEX 95 (94/9/EC). Electrical components fitted to the device comply with the ATEX requirements.



Application, Characteristics, Technical Data

Design and function

The spring-loaded safety relief valve SL 10 is used for reducing short-term pressure surges upstream of gas consumption systems or preventing an inadmissibly high pressure increase due to escaping gas, and is intended to protect downstream system components from excessive pressure levels.

The safety relief valve is composed of the actuator housing and the 'control device' functional unit. In the closed position, the gas flows into the actuator housing in the direction of the arrow. The internal measurement line port is used to pass the outlet pressure to be regulated to the bottom of the main diaphragm of the safety relief valve. It compares the actual value with the command variable preset by the force of the setpoint spring. The setpoint required in each case is set via the setting screw. When the setpoint is exceeded, the measuring movement will lift the actuator, allowing the gas to escape via the blow-off line. If the actual value falls below the setpoint, the measuring movement will close the actuator again automatically.

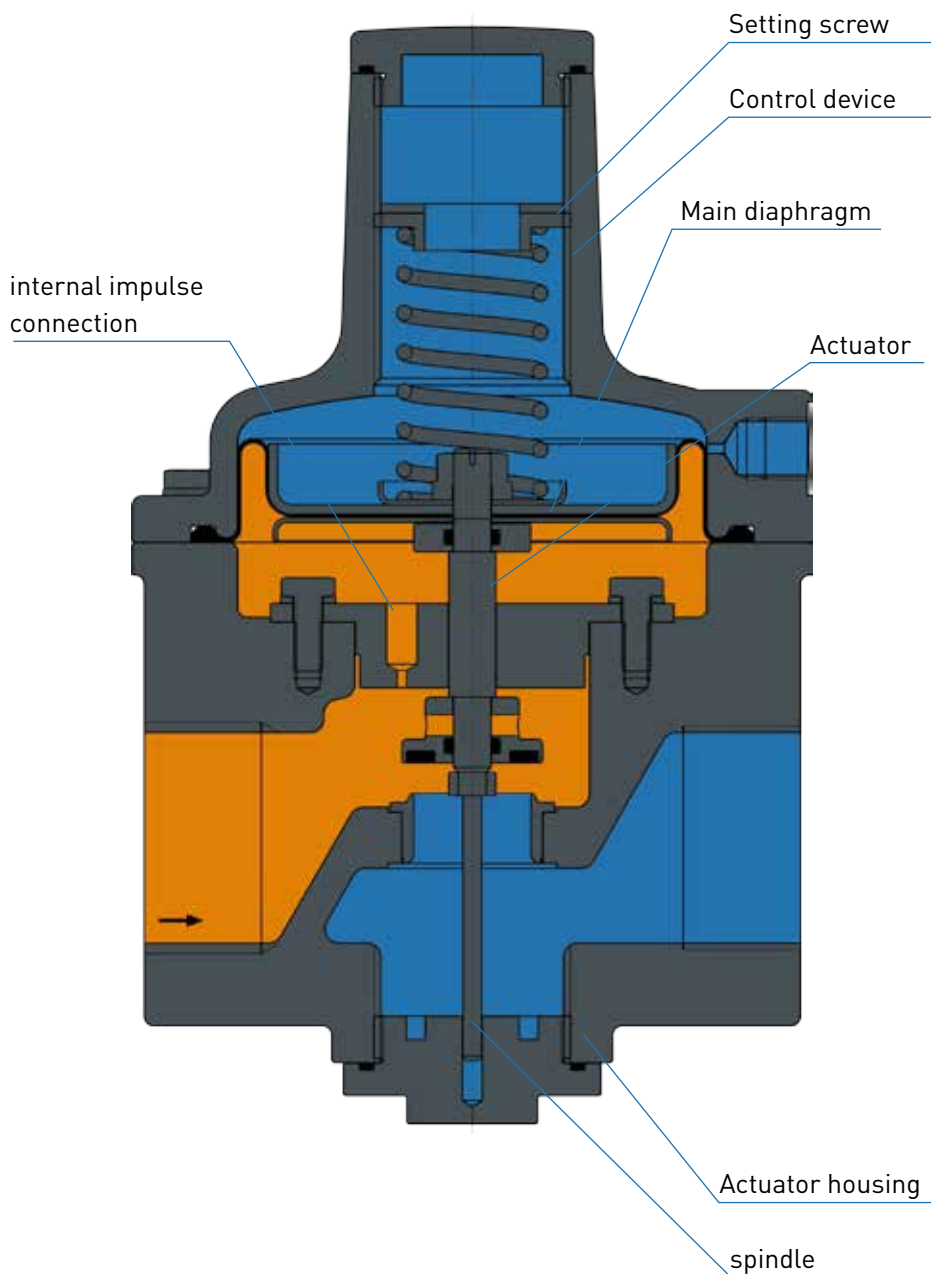

Option: Breather valve

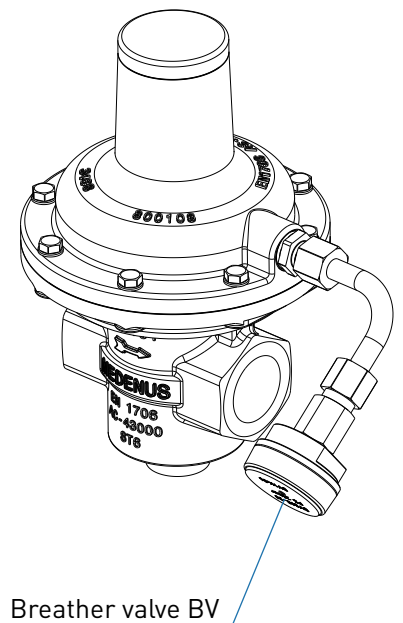

Application, Characteristics, Technical Data

Valve seat diameter, measuring movement diameter

Nominal size	Connection	Valve seat Ø (mm)	maximum flow rate (Nm ³ /h)	control unit Ø (mm)
DN 25	Rp 1	20	100	145
DN 40	Rp 1½	25	300	145
DN 50	Rp 2	25	300	145

Control unit setpoint spring table

control unit Ø (mm)	Spring data	
	Spring no.	Colour [RAL]
145		
20 - 39	FG100	9005
35 - 71	FG101	5015
55 - 131	FG102	6018
105 - 275	FG103	3020
215 - 575	FG104	5010
415 - 1050	FG105*	6010
900 - 1950	FG106**	7035
1750 - 3560	FG107**	1028

*) with high-pressure spring plate (HD1)

***) with high-pressure spindle (HD2)

Dimensions, Connection and Weight

Dimensions and weight

Nominal size DN	Connection	control unit (mm)	A (mm)	B (mm)	L (mm)	HD2 (mm)	X (mm)	Weight (kg)	Weight HD2 (kg)
25	Rp 1	145	173	57	100	112	180	2.5	0.4
40	Rp 1½	145	173	61	140	112	180	3.5	0.4
50	Rp 2	145	173	61	160	112	180	3.5	0.4

Dimensional drawing

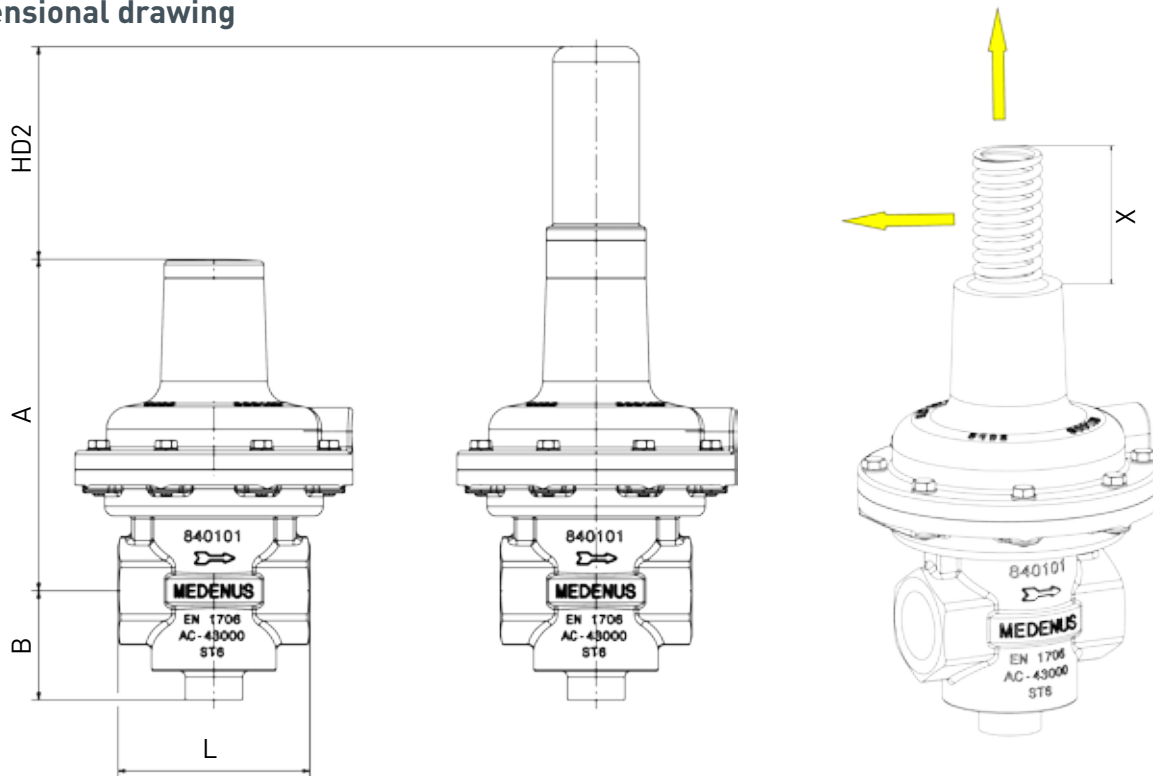

Example:

SL10/Rp 1" with HD2

Weight (SRV + HD2): 2.5 kg + 0.4 kg = 2.9 kg

Dimensions (A + HD2): 173 mm + 112 mm = 285 mm

Connections

Nominal size	Breather line
DN 25	Connection* for: Tube 10 x 1.5 (thread G 1/4)
DN 40	
DN 50	

Note

Observe the following publications in relation to installation, start-up and maintenance:

DVGW - work sheets G 491 and G 600

Operating and Maintenance Instructions SL 10

For all nominal sizes, the direction of flow is indicated by an arrow on the housing.

*) Threaded pipe connections to DIN EN ISO 8434-1 (DIN 2353)

Order data

Example:

		Safety relief valve: SL10/Rp1"/BV/WAZ/So				
		Order code:				
		SL10	Rp1"	BV	WAZ	So
Order selection	Designation					
Type						
SL10	SL10	SL10				
DN - Nominal size	Table p. 8		Rp1"			
Accessories						
without	-					
Breather valve	BV			BV		
Acceptance test certificate to EN 10204/3.1						
without	-					
with acceptance test certificate	WAZ				WAZ	
Special model	So*					So

DN - Nominal size

Type	Rp 1"	Rp 1½"	Rp 2"
SL10	X	X	X

We recommend, for systems with regulators
 up to DN 100 our SL10-Rp 1"
 up to DN 150 our SL10-Rp 1 ½"
 up to DN 200 our SL10-Rp 2"

- *] e.g.:
- Coating with epoxy resin in RAL colours
 - Oxygen model

In every selection group, there is only one option that can be selected.



THE MEDENUS PLUS

10 reasons for good business relations

1. Consultancy expertise and quality standards developed over decades
2. Broad and proven standard range of feedback controllers
3. Modern, fast and efficient production for serial orders and for individual orders
4. Customized design of pressure regulators and vacuum regulators as well as special designs
5. Guaranteed deadline compliance with a delivery time guarantee
6. Fast response time in all matters
7. Sufficiently large parts storage for production and spare parts
8. Customized theory & practice training courses
9. Modular design right across the entire product range to facilitate optimized handling of spare parts
10. Made in Germany